

WS 211V | CA

Vandal resistant IP emergency call station with built-in Axis camera



Built-in
Axis
camera

High
volume

Weather-
proof
IP66

16kHz
eHD Voice

Vandal
resistant
IK09

Professional audio and video

The vandal resistant station with built-in high-performance Axis camera is developed for areas with high requirements on safety and system integration. The integrated technology allows excellent speech quality and comprehensibility independent of background noise.

The 3 mm stainless steel front panel with poke protection and special screws protects against vandalism. The robust construction provides full protection against water, dirt and dust – IP rating IP66. The red emergency call button is easily visible from a considerable distance and can quickly be activated in emergency situations.

Features and highlights

- Compatible with third-party components, e.g. NVRs
- Multiple H.264 and MJPEG streams possible
- Excellent video quality, including HDTV 720p and H.264
- Vandal resistant and detection of tampering attempts such as blocking or spray-painting
- Backlit emergency call button
- Supports DSP features such as OpenDuplex®, audio monitoring and loudspeaker/microphone surveillance

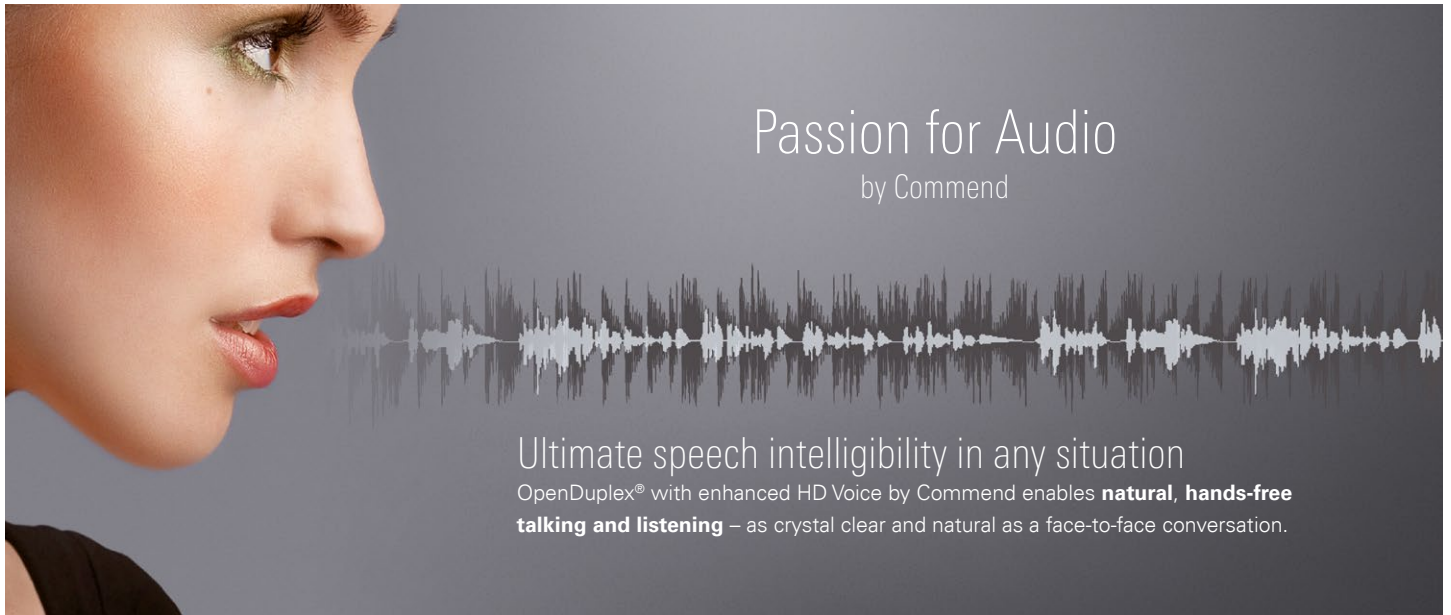





Passion for Audio

by Commend

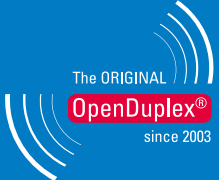
Ultimate speech intelligibility in any situation

OpenDuplex® with enhanced HD Voice by Commend enables **natural, hands-free talking and listening** – as crystal clear and natural as a face-to-face conversation.

 <p>Natural communication</p>	 <p>Enhanced HD Voice</p>	 <p>High volume</p>	<p>IVC</p> <p>Intelligent Volume Control</p>	 <p>Loudspeaker/microphone surveillance</p>
--	--	--	--	--

Audio // Basics

eHD Voice	Enhanced HD Voice by Commend transfers the audio signal at a bandwidth of 16 kHz , thus capturing the entire frequency spectrum of the human voice.
STI	Speech Transmission Index 0.96 – measured under acoustic laboratory conditions (STI is a standard measure for speech intelligibility; it has a possible maximum value of 1.00, which corresponds to perfect intelligibility)
Sound pressure level	High volume up to 99 dB
Amplifier	Highly efficient class-D amplifier with 2.5 W
Microphone	Omnidirectional electret condenser microphone for max. 7 m (23 ft) speaking distance
Loudspeaker	2 x 8 Ω loudspeaker with humidity-resistant special membrane type for optimum sound quality

Learn more audio.commend.com

Audio // Functions

- Loudspeaker/microphone surveillance** – ensures the availability of the Intercom station while reducing the need for manual verification of its functionality
- Audio monitoring** – fully automated emergency calls triggered by defined noise levels for more security
- Peer-to-peer audio** – reduces network and server load to ensure efficient use of resources
- Audio recording** and lip-synchronous audio/video recording of conversations for documentation and evidence keeping purposes
- Conference call function** for simultaneous talking with multiple conversation partners
- Speech activity detection** senses when calls are finished (no microphone signal) and terminates the connection automatically
- Simplex mode** for applications requiring controlled communication – e. g. for security solutions based on the “push-to-talk/release-to-listen” method
- OpenDuplex®** for natural, hands-free communication
- IVC** (Intelligent Volume Control) automatically adjusts the device's volume setting to the ambient noise level
- Public address functions**

WS 211V I CA

Technical specifications

Technical data WS 211V I CA

IP rating:	IP66 (acc. EN 60529)
Mechanical impact resistance:	IK09 (acc. EN 62262)
Front panel:	stainless steel, 3 mm (0.12 in)
Microphone:	electret condenser microphone polar pattern: omnidirectional speaking distance: max. 7 m (23 ft)
Loudspeaker:	special membrane type for optimal sound quality sound pressure level: 85 dB/1 W/1 m (3.28 ft), 2 x 8 Ω
Amplifier:	integrated class-D amplifier with 2.5 W
Sound pressure level:	max. 99 dB
Handset, headset:	EM sensitivity: 14 mV _{eff} EM impedance: 3.3 kΩ EM supply: 2.5 V EP level: 850 mV _{eff} at 0 dBm0 EP impedance: 200 Ω
Input:	3 inputs for floating contacts (detection of 5 input states)
Output:	2 relay outputs (switch-over contact) max. 60 W (DC)/37.5 VA (AC) max. 2 A max. 60 VDC/30 VAC expected life: min. 5 x 10 ⁴ (2 A), 10 ⁵ (1 A)
Line output:	for connecting a loudspeaker module
Status indication:	multifunction LED (colours: red, green, blue)
Call button:	large emergency call button
Audio bandwidth:	16 kHz
Operating temperature range:	-25 °C to +60 °C (-13 °F to +140 °F)
Storage temperature range:	-25 °C to +60 °C (-13 °F to +140 °F)
Relative humidity:	up to 95%, not condensing
Connection:	pluggable screw terminals Ethernet: shielded RJ45 modular jacks
Cabling:	min. Cat. 5
Power supply:	PoE: IEEE 802.3af power consumption: class 0 (0.44 W to 12.95 W)
Device class:	ES1, PS2 as per IEC/EN 62368-1
Protocol:	lolP protocol based on UDP/IP
Data rate:	10/100 MBit/s (Full/Half Duplex)
Mounting:	flush mount kit WSFB 50V flush mount kit WSFB 50V FL surface mount kit WSSH 50V rain protection roof WSRR 50V
Dimensions (W x H x D):	with flush mount kit: 164 x 279 x 14 mm (6.46 x 10.98 x 0.55 in) with surface mount kit: 164 x 279 x 50 mm (6.46 x 10.98 x 1.97 in) (dimensions without camera dome)
Weight incl. package:	approx. 1,400 g (3.1 lbs)



Line length in LAN

The maximum line length of Cat. 5 cabling in a LAN is 100 m (328 ft) – e.g. from switch to Intercom station.

Extent of supply

- Intercom station
- Short reference
- Screws for mounting
- Snap-on ferrite

Technical data Axis camera

General

Memory and storage:	512 MB RAM, 256 MB Flash support for microSD/microSDHC/microSDXC card support for SD card encryption support for recording to NAS (Network-Attached Storage)
----------------------------	---

Camera

Image sensor:	1/2.9" progressive scan RGB CMOS
Lens:	2.8 mm, F2.0, 115°
Total horizontal camera angle of view (incl. mechanical adjustment range):	165°
Camera angle adjustment (mechanical):	± 25°
Light sensitivity:	HDTV 720p 25/30 fps with Lightfinder color: 0.06 lux at 30 IRE F2.0
Shutter time:	1/32,500 s to 2 s

Video

Video compression:	H.264 (MPEG-4 Part 10/AVC) Profile Baseline, Main and High MJPEG
Resolution:	160 x 90 to 1,280 x 720 pixels
Frame rate:	up to 25/30 fps (50/60 Hz) in all resolutions
Video streaming:	multiple, individually configurable videostreams in H.264 and MJPEG, AXIS Zipstream technology in H.264, controllable frame rate and bandwidth VBR/CBR H.264
Image settings:	compression, colour, brightness, sharpness, contrast, white balance, exposure control, exposure zones, fine tuning of behaviour in low-light conditions, rotation (0°, 90°, 180°, 270°) including Corridor Format, text and image overlay, 20 individual privacy masks, mirroring of images, Traffic Light mode

Network

Security:	password protection, IP address filtering, HTTPS ²⁾ encryption, network access control, digest authentication, user access log, centralized certificate management
Supported protocols:	IPv4, IPv6, HTTP, HTTPS ²⁾ , SSL/TLS ²⁾ , QoS Layer 3 DiffServ, FTP, SFTP, CIFS/SMB, SMTP, Bonjour, UPnP™, SNMP v1/v2c/v3 (MIB-II), DNS, DynDNS, NTP, RTSP, RTP, TCP, UDP, IGMP, RTCP, ICMP, DHCP, ARP, SOCKS, SSH

²⁾ This product includes software developed by the OpenSSL Project for use in the OpenSSL Toolkit (www.openssl.org), and cryptographic software written by Eric Young (eay@cryptsoft.com).

System integration

Application Programming Interface:	open API for software integration, including VAPIX® and AXIS Camera Application Platform, AXIS Video Hosting System (AVHS) with One-Click Connection, ONVIF® Profile S and ONVIF® Profile G
Analytics:	included: AXIS Video Motion Detection, active tampering alarm ³⁾ supported: AXIS Perimeter Defender support for AXIS Camera Application Platform enabling installation of third-party applications
Event triggers:	analytics, time scheduled, edge storage events
Event actions:	record video: SD card and network share upload images or video clips: FTP, SFTP, HTTP, HTTPS, network share and email pre- and post-alarm video or image buffering for recording or upload notification: email, HTTP, HTTPS, TCP and SNMP trap PTZ: PTZ preset, start/stop guard tour overlay text
Data streaming:	event data

³⁾ For detection of tempering attempts in static and non-crowded scenes.



System requirements

Intercom Server

- GE 800 (min. PRO 800 3.0) with G8-IP (min. G3-8-IP 4.0B01) or
- GE 300 (min. PRO 800 3.0) with G3-IP (min. G3-8-IP 4.0B01) or
- IS 300 (min. PRO 800 3.0) or
- S3/S6 (min. version 7.1) or
- VirtuoSIS (min. version 3.0)
- For displaying the camera image on monitor modules of the WS series: min. upgrade licence PRO3U

Backwards compatibility to GE 700 or GE 200

- GE 700 (min. PRO 5.7) with G7-DSP-IP or
- GE 200 (min. PRO 5.7) with G2-DSP-IP
- Detected as ET 908 – therefore, they can only be used with the feature scope of an ET 908
- Firmware download only possible with GE700-UPG or via IP Station Config!

Configuration software

- Configuration software min. CCT 800 3.0
- Configuration software IP Station Config (included in setup of CCT 800 3.0)

Network requirements

IP addresses and ports

- For the WS 211V I CA, the DHCP functionality is available. If DHCP is not used, the WS 211V I CA must have a fixed IP address.
- In case of a changing public IP address, dynamic registration of a WS 211V I CA is possible.
- Communication from the software IP Station Config is done via port 16399 (cannot be configured).
- Communication from the WS 211V I CA to the Intercom Server (UDP protocol) is done via port 16400 (configurable).

QoS requirements

- One-way delay max. 100 ms
- Jitter max. 50 ms
- 0% packet loss for perfect audio quality

Bandwidth

- Required bandwidth incl. protocol overhead per WS 211V I CA, for upload/download each: 96 kBit/s (speech and data – no video)
- Speech is compressed according to G.722 standard.

WS 211V | CA

Installation instructions

Connection

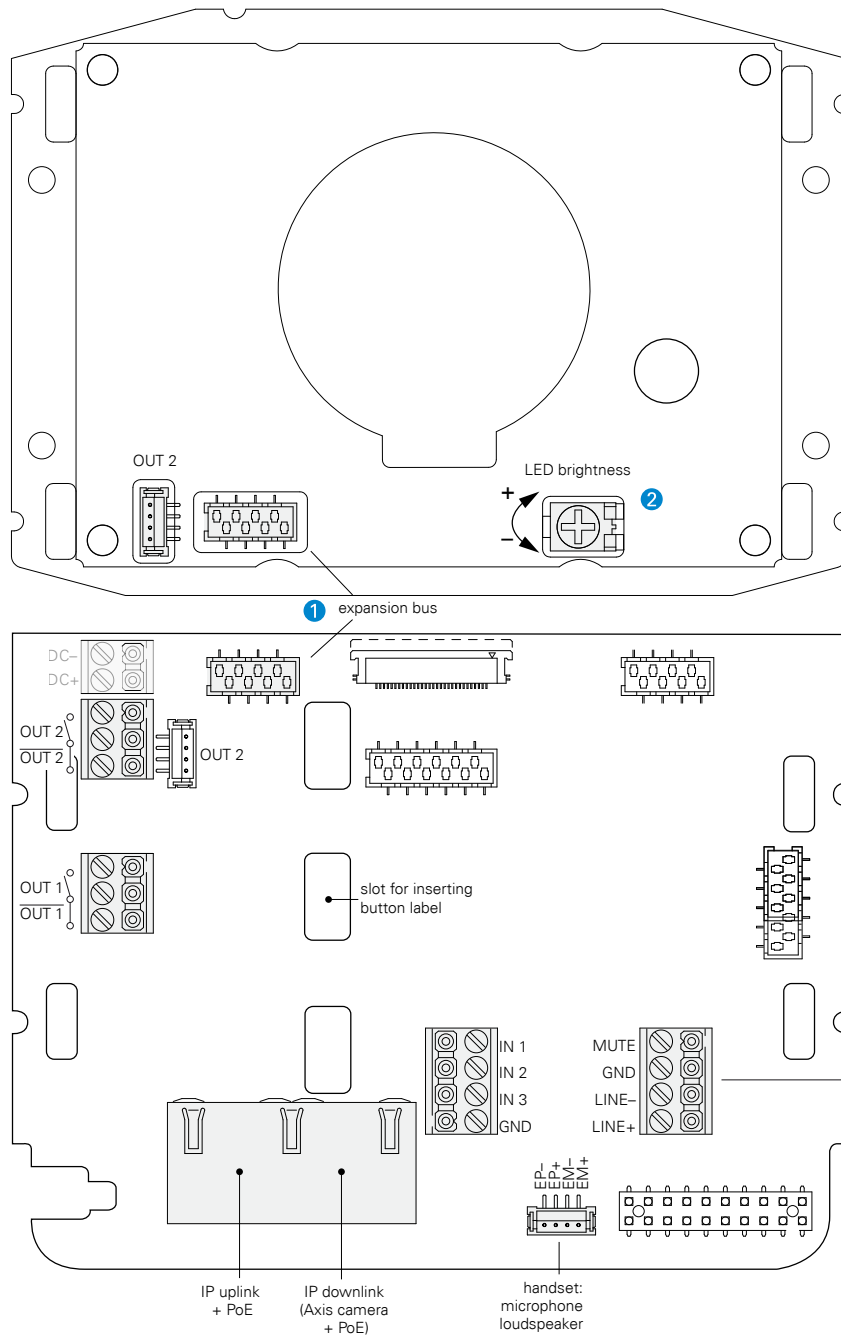

Camera illumination and heating control

- 1 The camera illuminator and the heating control are connected to the main board of the station via the expansion bus. In CCT 800, the device is shown with an additional EB2E2A device.
 - Use OUT 1 on the EB2E2A to switch the camera illuminator on and off. It is also possible to use OUT 1 as attendant contact, e.g. to switch on the camera illuminator at call setup.
- 2 To dim the camera illuminator, use the potentiometer on the camera board.
 - Use OUT 2 on the EB2E2A to switch the camera heating on and off.

Note:

It is recommended to keep the heating on permanently to avoid condensation on the camera glass in certain installation scenarios (e.g. inside metal columns). The same recommendation holds for environments where the station is exposed to large fluctuations in temperature and to high humidity.

Attention:

- No external power supply may be connected to the terminals "DC-" and "DC+"!
- PoE has to be connected to the RJ45 jack "IP uplink" (see connection diagram).
- The Axis camera is connected to the "IP downlink" jack of the station PCB.

Axis electronic module

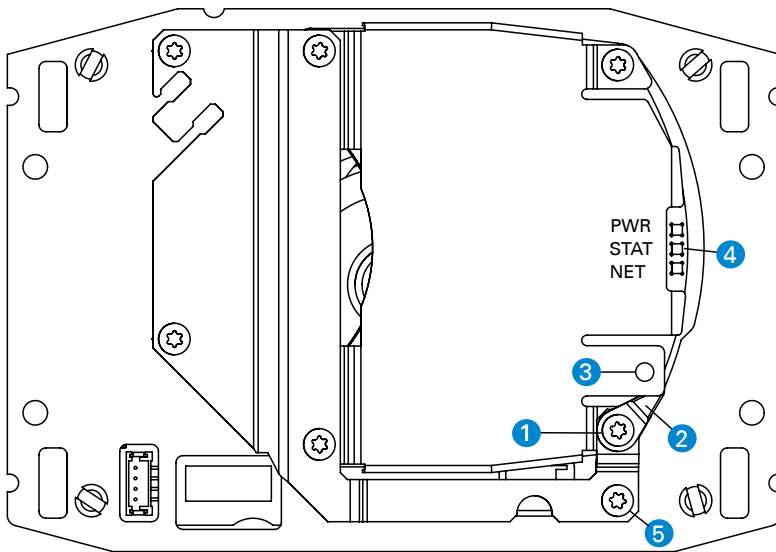
**Control button**

Follow the steps below to operate the control button:

- Loosen the screw **1** (Torx T8).
- Turn the safety lever **2** outwards.
- Push the control button **3**.
- Turn the safety lever **2** back into its original position and tighten the screw **1**.

Follow the steps below to reset the camera to the factory default settings using the control button:

- Disconnect the power supply from the camera.
- Press and hold the control button **3** and reconnect the power supply.
- Keep the control button pressed until the LED indicator **4** flashes amber.
- Release the control button. If the status LED **4** turns green, the process is completed.

Attention:

After a reset, the camera must be reconfigured, otherwise the camera image would appear 180° upside down.

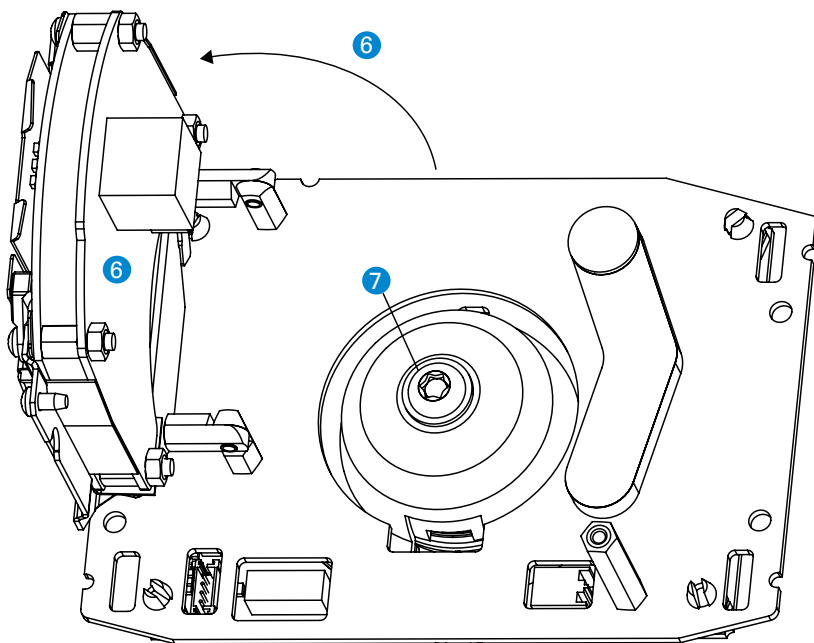
**Adjusting the camera**

Follow the steps below to adjust the angle of the camera:

- Loosen the screw **5** (Torx T8).
- Open up the Axis electronic module **6**.
- Loosen the locking screw **7** (Torx T25) on the rear of the camera.
- Adjust the camera in the desired angle (max. 25° in every direction).
- Tighten the locking screw **7**.
- Move the Axis electronic module **6** back into its original position.
- Tighten the screw **5**.

First connection

The IP address is assigned directly via a DHCP server. If the network does not have a DHCP server, the default address "192.168.0.90/24" is used.

The web interface can be accessed via a web browser using the URL "http://<IP address>". Additionally, the URL "http://<username>:<password>@<IP address>/axis-cgi/mjpg/video.cgi" can be entered in a web browser to directly access the MJPEG stream.

Note:

For further information on installation and settings, see Axis manual "P3904-R Mk II".

Login for Axis web interface

User name: root
Password: root

Attention:

After a reset, the password has to be configured manually.

Dimensions front panel

Measuring units in mm (in), not to scale!

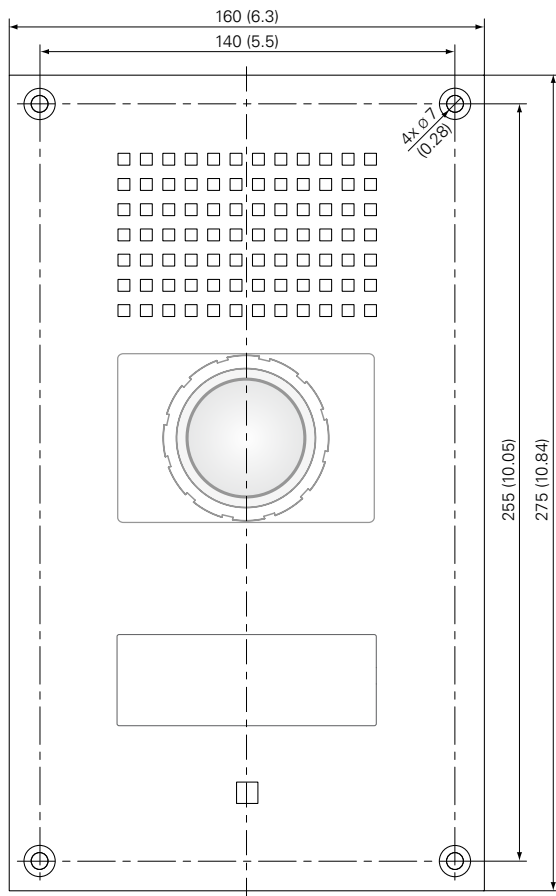

Recommended mounting height

It is recommended to mount the upper edge of the station approx. 1.65 m (5.4 ft) from the finished floor. Adapt the mounting height to individual needs.

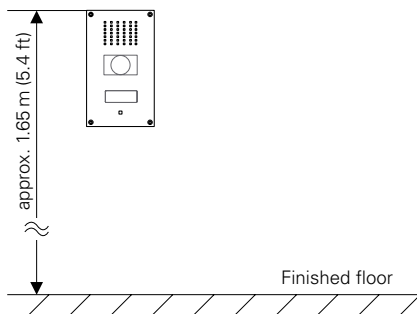

Quality tested. Reliable. Smart.

COMMEND products are developed and manufactured by Commend International in Salzburg, Austria.

The development and manufacturing processes are certified in accordance with **EN ISO 9001:2015**.



The technical data contained herein has been provided solely for informational purposes and is not legally binding. Subject to change, technical or otherwise. lolP®, OpenDuplex® and Commend® are trademarks registered by Commend International GmbH. All other brands or product names are trademarks or registered trademarks of the respective owner and have not been specifically earmarked.

Precautions

- This is a Class A product (standard EN 55032). In a domestic environment, this product may cause radio interference in which case the user may be required to take adequate measures.
- Cables must never be placed in the space between the black protective plate of the Axis camera module and the wall mount box. Doing so may cause damage to the Axis camera or compromise the tightness of the Intercom station's housing.
- All connected circuits shall fulfill the requirements for ES1 (cf. SELV acc. IEC/EN 60950-1) and PS2 (Limited Power Source) as per IEC/EN 62368-1.
- Let the device cool down completely before touching any parts of it.
- Unplug all Ethernet cables before performing any maintenance work on the device.
- Before using the device, ensure that all cables are undamaged and properly connected
- This device may only be installed, replaced and maintained by trained and properly qualified personnel (device class: ES1, PS2 acc. IEC/EN 62368-1). The connectors are subject to possible high transient voltage surges. The device is intended for appropriate installation in locations where operating personnel cannot come into contact with uninsulated wires.
- Devices belonging to another earthing network must not be connected to the device's connectors.

Mounting instructions

- Do not expose the station to extreme temperatures (see "Technical data").
- Observe the country specific standards for installation, mounting and configuration.
- When opening the station, ESD precautions must be observed.
- The station may only be opened by authorised service engineers.
- For flush mounting, the flush mount kit WSFB 50V or WSFB 50V FL is required (available separately).
- For surface mounting, a surface mount kit WSSH 50V is required (available separately).
- Use shielded Ethernet cables only.
- If the Intercom station is installed in a third-party column, ensure sufficient air circulation to prevent condensation and extreme heat generation (e.g. by means of ventilation slots at the top and bottom of the column). It is recommended to use ventilation grilles with small animal protection.

A strong worldwide network

COMMEND is represented all over the world by local Commend Partners and helps to improve security and communication with tailored Intercom solutions.

www.commend.com