

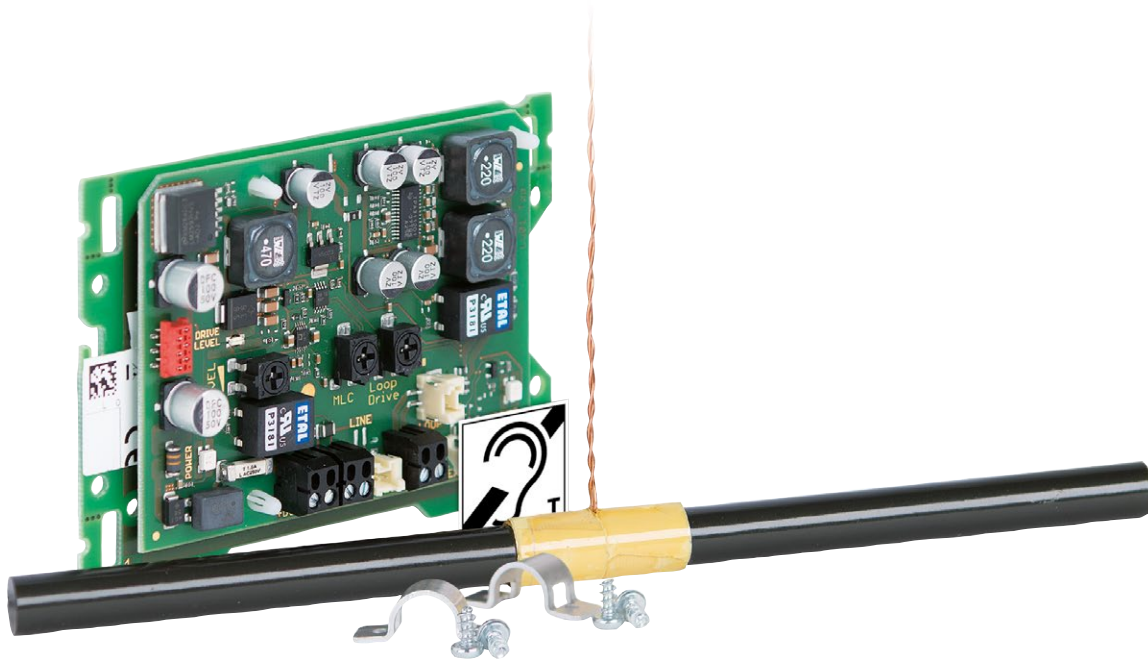

WSEB IL

Induction Loop Amplifier Module for barrier-free communication



IEC 60118-4
compliant

Flexible
integration

Communication and security for everyone

Induction loop amplifier modules for sound transmission to hearing aids are an essential part of Commend's product portfolio. Upgrading WS stations to be barrier-free has never been easier.

As an add-in circuit board with on-board induction loop, the module may be small in size but is a huge advantage for users of hearing aids. Designed specifically for public locations such as building reception areas or on-street help points, the modules deliver Intercom audio in high Commend quality directly to hearing aids.

Being hard of hearing doesn't have to be a barrier – especially with Commend induction loop modules. Take the opportunity to upgrade your system to be barrier-free and provide optimum conditions for all Intercom users with the benefits of the world's leading Intercom technology.

Features and highlights

- A fully integrated, IEC 60118-4 compliant induction loop system enables wearers of hearing aids to receive Intercom audio signals in clear, uninterrupted quality.
- Flexible integration into vandal resistant or polycarbonate WS stations without camera or TFT-display
- Energy-efficient and power-saving technology with low heat generation.
- Functions as MLC (Metal Loss Correction) and AGC (Automatic Gain Control) for easy startup and faultless operation.

WSEB IL

Technical specifications

Technical data

Input:	Input impedance 10 kΩ sensitivity: -15 dB u for max. output overload level: + 10 dBu
Output:	drive voltage: max. 6.5 V _{rms} drive current: 2.8 A continuous 1 kHz sine wave loop resistance: 0.10 Ω to 1.0 Ω resistive or 1.5 Ω maximum reactive impedance
Frequency response:	80 Hz to 8 kHz: -3 dB
MLC (Metall loss correction):	0 to -3 dB/octave
Operating temperature range:	-20 °C to +70 °C (-4 °F to +158 °F)
Storage temperature range:	-20 °C to +70 °C (-4 °F to +158 °F)
Relative humidity:	up to 95%, not condensing
Connection:	pluggable screw terminals JST plug (type: PAP-02v-s)
Power supply:	external power supply 15 – 26 VDC (max. power consumption 8 W)
Dimensions (W x H x D):	245 x 145 x 83 mm (9.6 x 5.7 x 3.3 in)

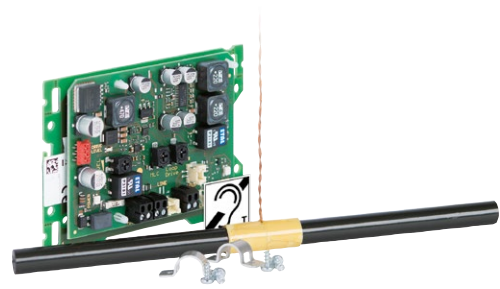

Extent of supply

- Induction loop amplifier module
- Induction loop and mounting kit
- Sticker with hearing loop icon
- Line-in connection cable

Requirements

- Power supply: 15 – 26 VDC
- WS station without camera or TFT display
- Flush mount kit (WSFB 50x) or surface mount kit (WSSH 50x)

Mounting instructions/restrictions

- Do not expose the Induction loop module to extreme temperature.
- Observe the country specific standards for installation, mounting and configuration.
- When opening the stations ESD precautions must be observed.
- The housing may only be opened by authorised service engineers.
- The requirements of the standard IEC 60118-4 are met by the installation at the specified height and at the correct distance from a single person when properly commissioned.
- Metal structures significantly affect the performance of the induction loop system. The magnetic field generated by an induction loop system induces a current in surrounding metal structures, which weakens the magnetic field and may cause losses. Examples of metal structures:
 - Reinforced concrete
 - Beams, girders, constructions made of metal
 - Metal facade cladding and walls
 - Metal box constructions (escalator, lift)

WSEB IL

Installation instructions

Quick start

Please follow the instruction below to install the Induction loop amplifier module:

- Open the WS station (see respective short reference).
- Disconnect the station from the Intercom network and if used, from the external power supply.
- Mount the Induction loop on the surface or flush mount box as shown in the following picture.

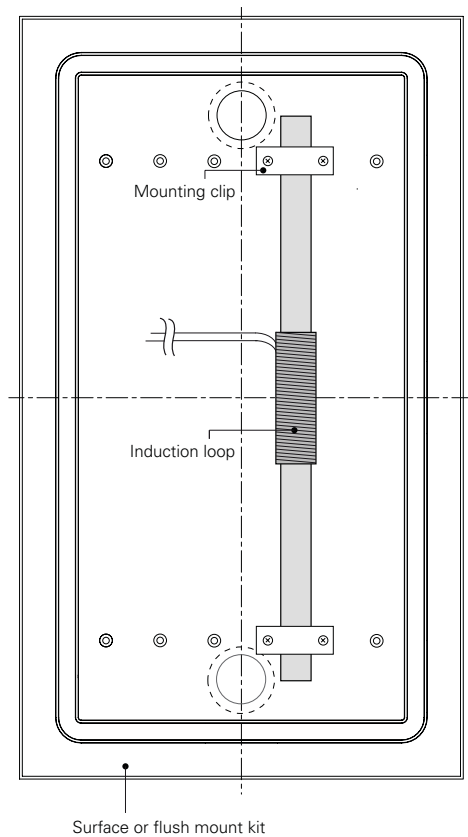

- Snap the Induction loop amplifier in the module in the slot of the WS station:
 - It is only possible to snap the module in the middle slot of the WS station.
 - If a camera module or a TFT-Display module is used in the middle slot, it is not possible to mount the induction loop amplifier module.

Note:

It is mandatory to install the induction loop on the right side of the housing, as shown in the connection diagram. Otherwise disturbing hum may occur. For the installation use the attached mounting clips and screws (in extent of supply).

Recommended mounting height of the induction loop

With a mounting height of approx. 1,100 mm (43 in), AFIL signals are ideally transmitted for children, wheelchair users and standing adults. A distance of approx. 500 mm (20 in; arm's length) is recommended between the Intercom station and the inductive hearing aid. If required, adjust the mounting height to the respective requirements and local regulations.

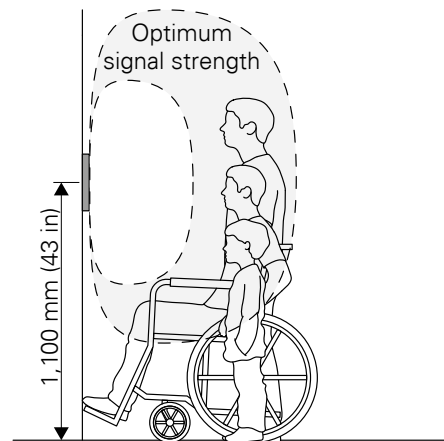

- Carry out the connection of the induction loop, signal input and power supply.
 - Connect the loop cable (polarity does not matter) via the screw terminals as shown in the following picture.
 - Connect line-in with the connection cable (in the extent of supply) - as shown in the following picture.
 - Connect power supply (15 VDC - 26 VDC) as shown in the following picture.

Note: If an external power supply is used for the terminal, it is possible to use this power supply also for the Induction loop amplifier module.

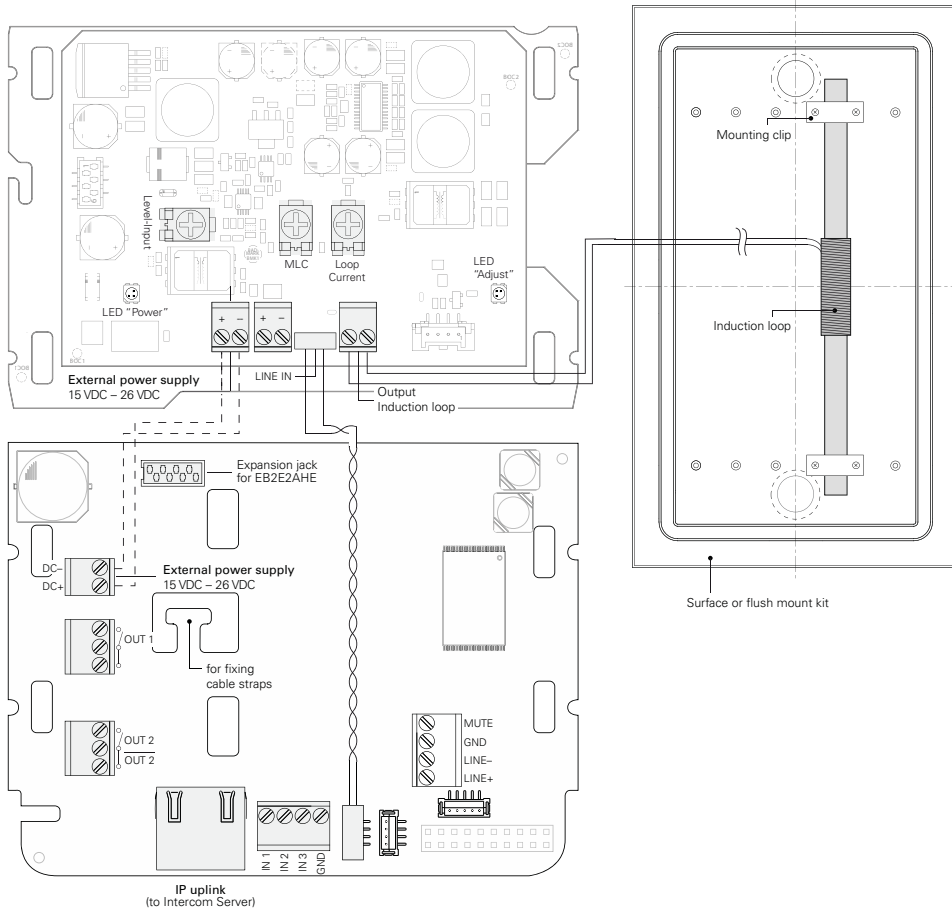

- Switch on the external power supply and check if the green "Power" LED illuminates.
- The potentiometers "Level-Input", "MLC" and "Loop Current" are preset at factory delivery.
- Test the system performance with a loop receiver or a field strength meter. Adjust the power if necessary. Consider the respective standards when doing so.
 - Level-Input: Adjust the level of the input signal. The LED lights up green when the input level is sufficient.
 - Loop Current: Adjust the signal strength of the induction loop.
 - MLC: Metallic surfaces may reduce the transmission of higher frequencies. Adjust a sound that is too muffled by reducing low-frequency signal components.
- Mount the Intercom station – see short reference surface / flush mount kit.
- Place the sticker with the hearing loop icon onto the frontplate of the Intercom station.

Quality tested. Reliable. Smart.

COMMEND products are developed and manufactured by Commend International in Salzburg, Austria.

The development and manufacturing processes are certified in accordance with **EN ISO 9001:2008**.



The technical data contained herein has been provided solely for informational purposes and is not legally binding. Subject to change, technical or otherwise. IoIP®, OpenDuplex® and Commend® are trademarks registered by Commend International GmbH. All other brands or product names are trademarks or registered trademarks of the respective owner and have not been specifically earmarked.

A strong worldwide network

COMMEND is represented all over the world by local Commend Partners and helps to improve security and communication with tailored Intercom solutions.

www.commend.com